

A3WS

12 AND 17 METER BEAM









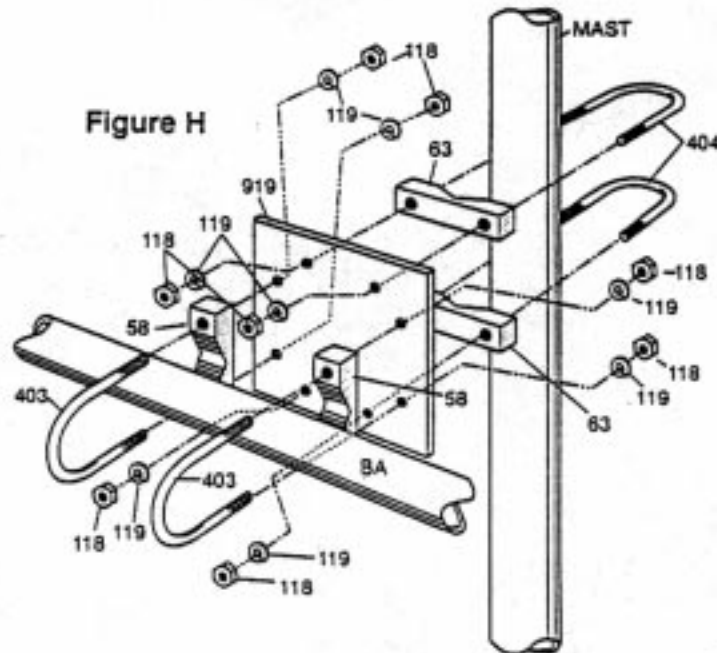

951370(5/90)

PLEASE NOTE: THIS ILLUSTRATION REPLACES *FIGURE H* IN THE A3WS ASSEMBLY MANUAL.

In order to make the A3WS more secure on a mast, our research and development team has added two V-blocks (part # 173658) to the masting hardware.

BOOM TO MAST ASSEMBLY



KEY	P/N	DISPLAY	DESC	SIZE	QTY
58	173658		V-BLOCK (Fits 403 U-Bolt)	3-1/2" (8.9 cm)	2
63	170063		V-BLOCK (Fits 404 U-bolt)	3-1/2" (8.9 cm)	2
118	010118		HEX NUT	5/16" (.8 cm)	8
119	010119		LOCK WASHER	5/16" (.8 cm)	8
403	010403		U-BOLT	3" x 1-7/8" (7.6 x 4.8 cm)	2
404	010404		U-BOLT	3-1/4" x 2-7/16" (8.3 x 6.2 cm)	2
919	190919		MOUNTING PLATE	6" x 6" (15.2x15.2 cm)	1

Your Cushcraft antenna is designed and manufactured to give top performance and trouble free service. All hardware is stainless steel. The antenna will perform as specified if the instructions and suggestions are followed and care is used in assembly and installation. When checking the components received in your antenna package use the parts lists in each section. It is easiest to identify the various dimensions of tubing by separating them into groups of the same diameter and length. If you are unable to locate any tube or component, check the inside of all tubing. **IMPORTANT:** save the weight label from the outside of the carton. Each antenna is weighed at the factory to verify the parts count. If you claim a missing part, you will be asked for the weight verification label. There is a master parts list on page 3.

LOCATION

Location of the antenna is very important. Surrounding objects such as trees, power lines, other antennas, etc. will seriously reduce efficiency. To minimize the effects of surrounding objects, mount the antenna as high and in the clear as possible. If metal guy wires are used, they should be broken with strain insulators.

WARNING: THIS ANTENNA IS AN ELECTRICAL CONDUCTOR. CONTACT WITH POWER LINES CAN RESULT IN DEATH, OR SERIOUS INJURY. DO NOT INSTALL THIS ANTENNA WHERE THERE IS ANY POSSIBILITY OF CONTACT WITH OR HIGH VOLTAGE ARC-OVER FROM POWER CABLES OR SERVICE DROPS TO BUILDINGS. THE ANTENNA, SUPPORTING MAST AND/OR TOWER MUST NOT BE CLOSE TO ANY POWER LINES DURING INSTALLATION, REMOVAL OR IN THE EVENT PART OF THE SYSTEM SHOULD ACCIDENTALLY FALL. FOLLOW THE GUIDELINES FOR ANTENNA INSTALLATIONS RECOMMENDED BY THE U.S. CONSUMER PRODUCT SAFETY COMMISSION AND LISTED IN THE ENCLOSED PAMPHLET.

Plan your installation carefully. If you use volunteer helpers be sure that they are qualified to assist you. Make certain that everyone involved understands that you are in charge and that they must follow your instructions. If you have any doubts at all employ a professional antenna installation company to install your antenna.

MOUNTING

The mast mount bracket will accommodate a 1.25"-2" (3.18-5.08 cm) mast. Heavy wall tubing should be used for the mast. A good heavy duty antenna rotator will provide the best service and longest life. Often it is desirable to mount several antennas on one mast. To keep possible interaction to a minimum, place your antennas as far apart as you can.

SYSTEM GROUNDING

Direct grounding of the antenna, mast and tower is very important. This serves as partial protection from lightning strikes and static buildup, and from high voltage which is present in the radio equipment connected to the antenna. A good electrical connection should be made to one or more ground rods (or other extensive ground system) directly at the base of the tower or mast, using at least 10AWG ground wire and non-corrosive hardware. For details and safety standards, consult the National Electrical Code. You should also use a coaxial lightning arrester. Cushcraft offers several different models, such as LAC-1, LAC-2 and the LAC-4 series.

ASSEMBLY

Assemble your antenna by following the directions and illustrations in steps 1 through 5. After the antenna is completely assembled, verify dimensions and element spacings for accuracy. Return to the section below for final tuning.

TUNING PROCEDURE

Tighten all nuts and recheck all dimensions per figures B & C. Because of variations in trap sizes, the overall dimensions may vary as much as 1.0" (2.54 cm) from the individual dimensions. This will not affect performance. Use the individual dimensions when adjusting your antenna. Your antenna is now ready for installation on your support.

NOTE: CHECKING THE VSWR NEAR THE GROUND WILL PROVIDE ERRONEOUS RESULTS. THE ANTENNA MUST BE IN IT'S FINAL WORKING POSITION FOR AN ACCURATE VSWR TEST.

30 METER ADD-ON KIT

Adding 30 meters to your A3WS beam is easy with the A103 add-on kit. You'll be on the air quickly operating on your new band because the A103 easily clamps to your A3WS. You can then operate on 30 meters. The kit comes complete with a reinforced center insulator, all stainless steel hardware and non-stretch lamcord® support line. Cushcraft makes it easy to add more excitement to your hobby.

MASTER PARTS LIST

KEY	PART #	DESCRIPTION	QTY
BA		1-5/8" x 12" (4.1 x 30.5 cm) aluminum tubing drilled and slotted both ends.	1
BB		1-1/2" x 84" (3.8 x 213.4 cm) aluminum tubing drilled one end	2
EA		1-1/8" x 72" (2.9 x 182.9 cm) aluminum tubing drilled for U-bolt, slotted both ends.	2
EB		1-1/8" x 36" (2.9 x 91.4 cm) aluminum tubing drilled one end, slotted both ends	2
EC		1" x 78" (2.5 x 198.1 cm) aluminum tubing slotted one end	2
ED		1" x 65" (2.5 x 161.1 cm) aluminum tubing slotted one end	2
EE		1" x 54" (2.5 x 137.2 cm) aluminum tubing slotted one end	2
EF		1/2" x 28" (1.3 x 71.1 cm) aluminum tubing	2
EG		1/2" x 25" (1.3 x 63.5 cm) aluminum tubing	4
TB-1		12 meter trap	6
10	010010	#8 internal tooth lock washer	6
11	010011	#8-32 hex nut	6
33	190033	Backing plate	2
46	050046	1-1/2" (3.8 cm) black plastic cap	2
	53	050053 1/2" (1.3 cm) black plastic cap	6
	63	170063 2" (5.1 cm) V-block	2
	84	010084 1/4" (.6 cm) lock washer	6
	85	010085 1/4" (.6 cm) hex nut	6
	96	122096 10" (25.4 cm) fiberglass insulator	1
	118	010118 5/16" (.8 cm) hex nut	8
	119	010119 5/16" (.8 cm) lock washer	8
	120	010120 #8-32 x 2" (5.1 cm) machine screw	2
	123	010123 #8-32 x 1-1/2" (3.8 cm) machine screw	2
	143	190143 1-1/8" (2.9 cm) aluminum bracket	3
	326	290326 Danger label	1
	402	010402 1-1/2" x 3-3/4" (3.8 x 9.6 cm) U-bolt	3
	403	010403 1-5/8" (4.1 cm) U-bolt	2
	404	010404 2-1/8" x 3" (5.4 x 7.6 cm) U-bolt	2
	409	030409 1 1/16" (1.7 cm) worm clamp	6
	410	030410 1" (2.5 cm) worm clamp	6
	411	030411 1-1/8" (2.9 cm) worm clamp	8
	413	030413 1-5/8" (4.1 cm) worm clamp	2
	453	100453 Terminal	2
	919	190919 6" x 6" (15.2 x 15.2 cm) mounting plate	1

#1 - BOOM ASSEMBLY

Place worm clamps (413) over the slotted ends of tube BA. Slide both BB sections into BA (figure A). Rotate them as required to align the holes for the 2" screws (120). Place the lock washer (10) and the hex nut (11) on the screws and tighten them. Tighten the worm clamps. Place the plastic caps (46) on the ends of the boom assembly.

FIGURE A

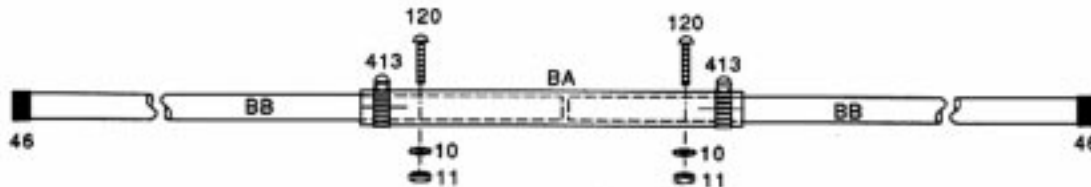

KEY	P/N	DISPLAY	DESC	SIZE	QTY						
BA			ALUM TUBE	1-5/8" x 12" (4.1 x 30.5 cm)	1	46	050046		PLASTIC CAP	1-1/2" (3.8 cm)	2
BB			ALUM TUBE	1-1/2" x 84" (3.8 x 213.4)	2	120	010120		MACHINE SCREW	#8-32 X 2 (5.1 cm)	2
10	010010		LOCK WASHER	#8	2	413	030413		WORM CLAMP	1-5/8" (4.1 cm)	2
11	010011		HEX NUT	#8-32	2						

FIGURE B

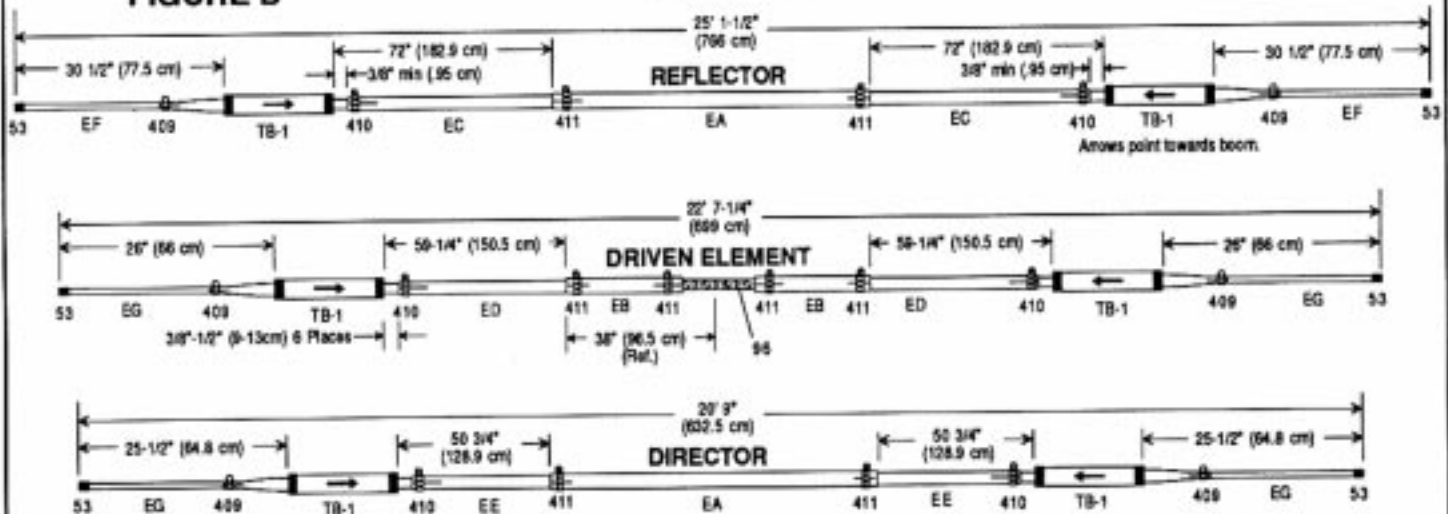

Because of variations in trap caps, the overall dimensions may vary as much as 1 inch from the individual dimensions. This will not affect performance. Always use the individual dimensions when adjusting your antenna.

KEY	P/N	DISPLAY	DESC	SIZE	QTY
EA			ALUMINUM TUBING	1-1/8" x 72" (2.9 x 182.9 cm)	2
EB			ALUMINUM TUBING	1-1/8" x 36" (2.9 x 91.4 cm)	2
EC			ALUMINUM TUBING	1" x 78" (2.5 x 198.1 cm)	2
ED			ALUMINUM TUBING	1" x 65" (2.5 x 165.1 cm)	2
EE			ALUMINUM TUBING	1" x 54" (2.5 x 137.2 cm)	2
EF			ALUMINUM TUBING	1/2" x 28" (1.3 x 71.1 cm)	2
EG			ALUMINUM TUBING	1/2" x 25" (1.27 x 63.5 cm)	4
TB-1			TRAP	12 METER	6
10	010010		INT. TOOTH LOCK WASHER	#8	2
11	010011		HEX NUT	#8-32	2
53	050053		PLASTIC CAP	1/2" (1.3 cm)	6
96	122096		FIBERGLASS INSULATOR	10"	1
123	010123		MACHINE SCREW	#8-32 X 1-1/2" (3.8 cm)	2
409	030409		WORM CLAMP	11/16" (1.7 cm)	6
410	030410		WORM CLAMP	1" (2.5 cm)	6
411	030411		WORM CLAMP	1-1/8" (2.9 cm)	8





#2 - ELEMENT ASSEMBLY

Assemble the elements per figure B. First place a worm clamp (410) over the slotted end of all EC, ED, and EE tubes. Then insert the traps (TB-1) into the slotted ends of the tubing leaving 3/8"-1/2" (9-13 mm) clearance between the edge of the trap and the slotted tubes (see figure B). Make sure the arrow on the trap faces the slotted tubing. Tighten all clamps.

Next place worm clamps (411) on the slotted ends of the EA tubes. Then insert the EC and EE tubes to the settings indicated in figure B and tighten the worm clamps.

Place worm clamps (411) on both ends of the EB tubes. Slide the end of the EB tube with the screw hole on the center insulator (96) as shown in figure E. Align the screw holes in the tubing with those in the insulator. Place an 8-32 screw (123) through the tubing and insulator hole and fasten it in place with nuts (10) and washers (11). Tighten all nuts. Insert the ED tubes into the EB tubes to the settings indicated in figure B and tighten the worm clamps.

Then place a worm clamp (409) on the end of all traps. Insert the end tubes, EF and EG into the ends of all traps. Set the proper dimensions per figure B and tighten the hose clamps. Place a plastic cap (53) on the ends of the EF and EG tubes.

KEY	P/N	DISPLAY	DESC	SIZE	QTY
33	190033		BACKING PLATE		2
84	010084		LOCK WASHER	1/4" (.6 cm)	6
85	010085		HEX NUT	1/4" (.6 cm)	6
143	190143		ALUMINUM BRACKET	1-1/2" (3.81 cm)	3
402	010402		U-BOLT	1-1/2" X 3-3/4" (3.8 x 9.6 cm)	3

#3 - ELEMENT MOUNTING

While referring to figure C, attach the director and reflector elements on the boom assembly using the U-bolts (402), aluminum brackets (143), backing plates (33), washers (84) and nuts (85) as shown in figure D. Then attach the driven element on the boom assembly using the U-bolt (402), aluminum bracket (143), washers (84) and nuts (85) as shown in figure E. *Note that there is no backing plate on the fiberglass insulator.*

Check all dimensions for the proper placement of elements on the boom as shown in figure C. Level the elements and tighten all the nuts on the U-bolts that hold the elements on the boom per figure F. Check all traps to make sure that the arrows are pointed towards the boom and the drain holes are facing the ground so that moisture will not build up in the traps.

FIGURE C

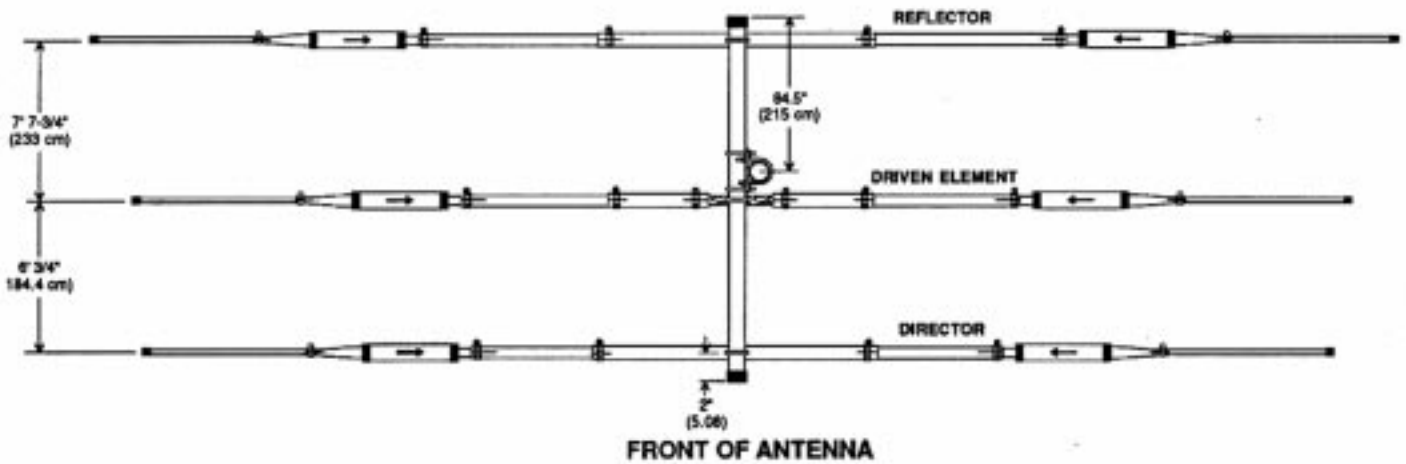

FIGURE D

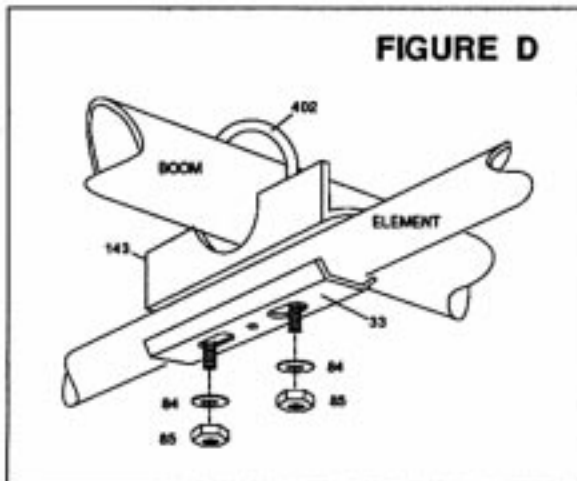

FIGURE E

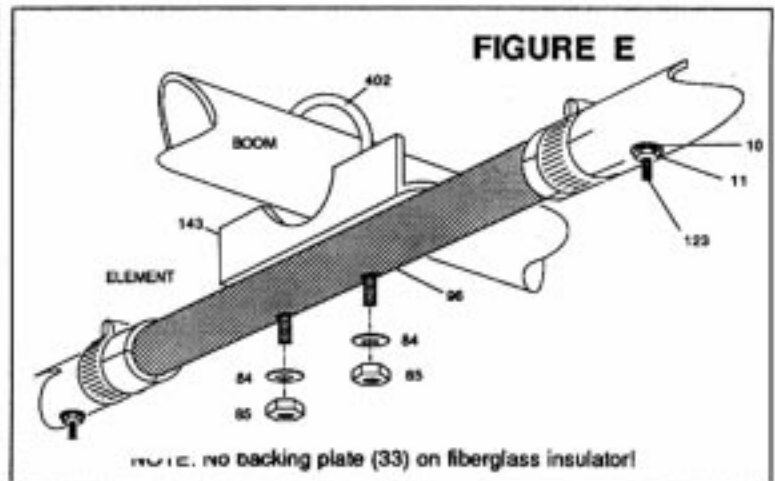
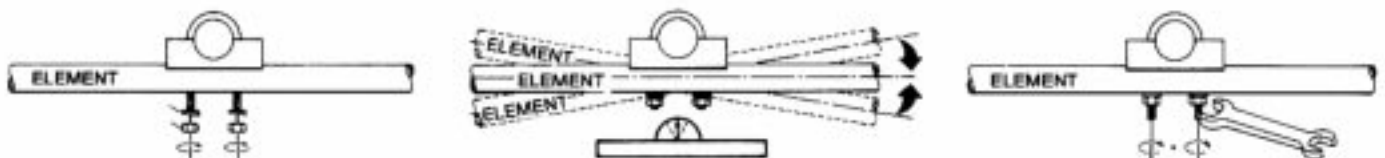

FIGURE F



#4 - RF CHOKE

A feedline should be prepared as shown in figure G using the solder terminals (453) provided. A 1:1 balun may be installed at the feedpoint but it is not required. We recommend using an RF choke made from 8 turns of RGB/U coaxial cable with 6 inch (15.3 cm) diameter as shown in figure 4. *Important--Do not use foam dielectric coax for your RF choke because when the coax is wound in a coil the center conductor may migrate away from the center and detune your choke.* Attach the RF choke to the driven element using washers (10) and nuts (11) as shown in figure G. Be sure to tape and seal the feedline against water at the point where the center dielectric and braid separate. Tape the feedline, between the feedpoint and the RF choke, to the boom. Tape the RF choke to the mast. If you plan to install the antenna in a salty or corrosive environment, you may want to consider coating all elements with a clear marine varnish or its equivalent after it is assembled.









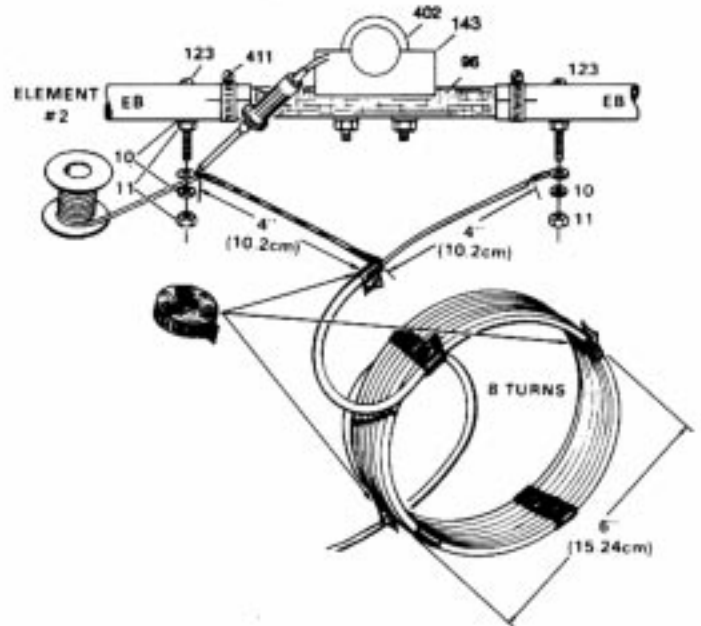

KEY	P/N	DISPLAY	DESC	SIZE	QTY
10	010010		LOCK WASHER	#8	2
11	010011		HEX NUT	#8-32	2
453			TERMINAL		2

FIGURE G



KEY	P/N	DISPLAY	DESC	SIZE	QTY
63	170063		V-BLOCK	2" (5.1 cm)	2
119	010119		LOCK WASHER	5/16" (.8 cm)	8
118	010118		HEX NUT	5/16" (.8 cm)	8
403	010403		U-BOLT	1-5/8" (4.1 cm)	2
404	010404		U-BOLT	2-1/8" x 3" (5.4 x 7.6 cm)	2
413	030413		WORM CLAMP	1-5/8" (4.1 cm)	2
919	190919		MOUNTING PLATE	6" x 6" (15.2x15.2 cm)	1

#5 - BOOM TO MAST ASSEMBLY

Attach the boom to your mast as shown in figure H. First attach the mounting plate (919) to the BA section of the boom using U-bolts (403), washers (119) and nuts (118). Then attach the mounting plate to the mast using the U-bolts (404), V-block (63), washers (119) and nuts (118). Then return to the assembly section on page 2 for final checkout and tuning procedure.

FIGURE H

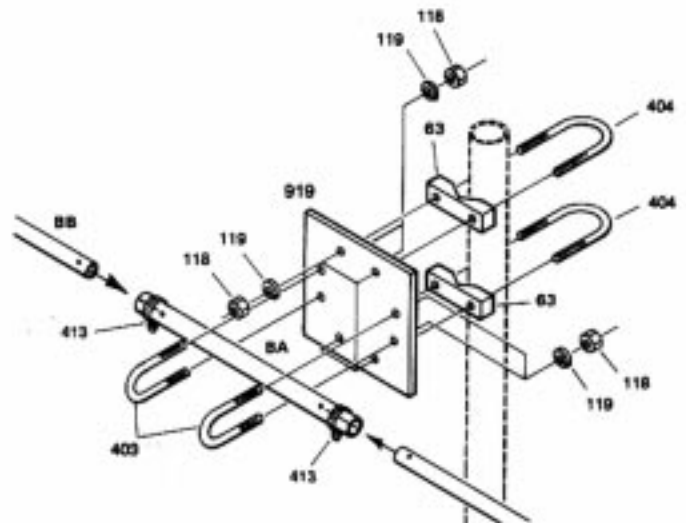

SPECIFICATIONS

Model	A3WS
Frequency Ranges	18.068-18.168 MHz 24.890-24.990 MHz
Forward Gain	8.0 dBd
Front to Back Ratio	25 dB typical
VSWR	1.2:1 typical
Bandwidth	300 KHz minimum
Power Rating	2000 Watts PEP
Feed Point Impedance	50 Ohms
Connector	Twin terminal stainless steel takes all coax
Boom Length	14' (426.7 cm)
Longest Element	25.1' (766 cm)
Turning Radius	14.4' (440 cm)
Mast Size Range	1.25"-2" (3.18-5.08 cm)
Wind Survival	80 mph (129 kph)
Wind Surface Area	4.1 ft ² (.38 m ²)
Weight	22.5 lbs. (10.2 kg)

LIMITED WARRANTY

Cushcraft Corporation, P.O. Box 4680, Manchester, New Hampshire 03108, warrants to the original consumer purchaser for one year from date of purchase that each Cushcraft antenna is free of defects in material or workmanship. If, in the judgement of Cushcraft, any such antenna is defective, then Cushcraft Corporation will, at its option, repair or replace the antenna at its expense within thirty days of the date the antenna is returned (at purchasers expense) to Cushcraft or one of its authorized representatives. This warranty is in lieu of all other expressed warranties, any implied warranty is limited in duration to one year. Cushcraft Corporation shall not be liable for any incidental or consequential damages which may result from a defect. Some states do not allow limitations on how long an implied warranty lasts or exclusions or limitations of incidental or consequential damages, so the above limitation and exclusion may not apply to you. This warranty gives you specific legal rights, and you may also have other rights which vary from state to state. This warranty does not extend to any products which have been subject to misuse, neglect, accident or improper installation. Any repairs or alterations outside of the Cushcraft factory will nullify this warranty.



48 PERIMETER ROAD, MANCHESTER, NH 03108
603-627-7877 / TELEX 4949472 / FAX 603-627-1764

SPECIFICATIONS SUBJECT TO CHANGE WITHOUT NOTICE